

## Cooling

Introducing our brand new range of fully co-ordinated appliances. Good looking on their own and fabulous together, they're not labelled **iQ** for nothing!

Saving energy is paramount to Siemens. As is clean design, first-class quality and smart thinking. Together, they're the backbone of our approach to everything we create. It's an attitude that runs right through our entire range of cooling products; from the smallest under the counter model to our stunning American style fridge freezers and right through to aCool, our latest top of the range models.

One of the major driving forces behind the creation of Siemens' brand new **iQ** range was to offer the customer the ability to achieve seamless design co-ordination between appliances. So the range comes in four distinct variants: **iQ100**, **iQ300**, **iQ500** and **iQ700**, that covers almost every kitchen appliance we make. With all the pieces designed to combine effortlessly with each other.

### **iQ 100**

#### The range

Typical Siemens style and build quality, offering exceptional value.

### **iQ 300**

#### The range

Good-looking mid-range appliances equipped with an attractive selection of smart features.

### **iQ 500**

#### The range

Oozing class and refinement, these machines unite first-class features with top-class technology.

### **iQ 700**

#### The range

Radical design allied with seriously innovative technology is the basis of these, our premium models.



All our built-in fridges, freezers and fridge freezers enjoy common features and benefits.

**Anti-spill safety glass shelving**

Accidents will happen. That's why our shelves have been designed to handle up to three quarters of a pint at least of spillage, without overflowing onto the area below.



**Humidity control panel**

The humidity control panel is found on most of our cooling appliances. This clever piece of technology alters the humidity of the vegetable compartment to optimise the appearance and preservation of the food.



**Removable magnetic door seals**

To make the door seals easy to clean or replace, we've made them magnetic. You simply pull the seal away from the inner door lining, give everything a good clean and then put it back. It really is that simple.



**Constant freezing**

All Siemens standard freezers have individual freezing elements for each drawer, which means that you can freeze food wherever there is space as the temperature is kept constant throughout the cabinet.

**First class thinking**

Four star freezing compartments allow frozen food to be stored at below -18°C. This means that fresh food can be frozen and stored for longer periods up to 12 months.



**Foamed in evaporator**

All models feature a foamed in evaporator to protect it from damage. The evaporator in a Siemens fridge is hidden behind the interior wall of the appliance, giving more interior space in the fridge. This smooth interior surface also makes the fridge easier to clean, looks more attractive, and reduces the potential of damaging an exposed evaporator.

Clean, fresh **design** is what makes our cooling appliances really stand out.



**A place for everything**  
In some models one of the safety glass shelves can be divided so taller items can be stored in the fridge. This is ideal for storing wine bottles inside the fridge. A handy bottle storage support is also provided on some models in the door to prevent bottles from rocking and tipping. It can hold up to four 2 litre bottles.

**Transparent design**  
The spacious robust freezer drawers keep temperature loss to a minimum. The drawers glide in and out easily, even when fully loaded, and the safety stops prevent the drawers from being accidentally pulled out. The freezer baskets have transparent drawer fronts, which look attractive and allow viewing of the contents without having to pull out the drawer.



**wineCooler**  
Why not protect your vintage wines with the Siemens wineCooler. It holds up to 32 bottles at the preferred temperature and gives you the cellar you've always wanted. The tinted frameless glass door with matching stainless steel handle gives your kitchen that sophisticated look.



# iQ700 aCool wineKooler

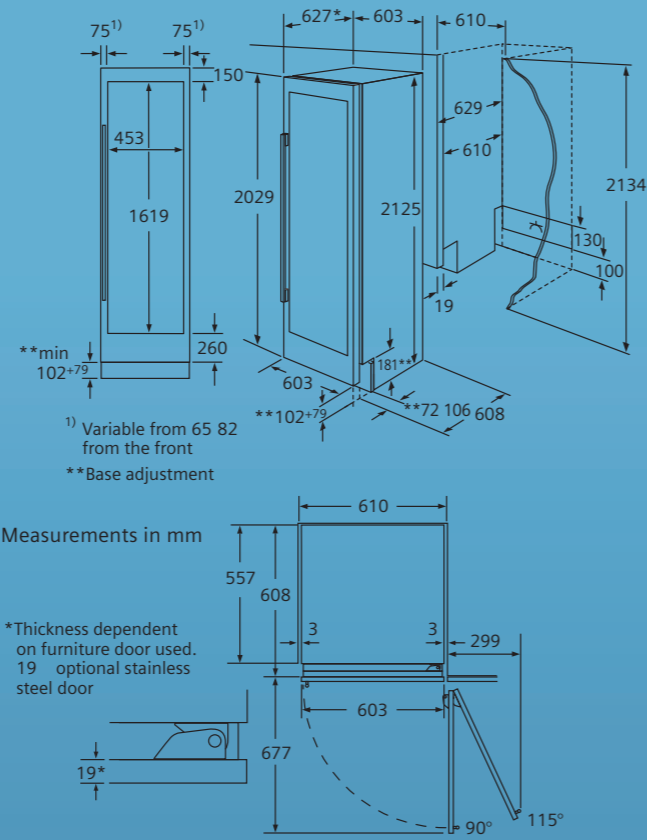

## aCool wineKooler CI24WP00

- Can be combined with other aCool models
- Electronic control with digital temperature display
- Audible alarm system in case of power failure or door left open
- Fridge section gross capacity: 394 litres/13.9 cu.ft
- Storage capacity for up to 98 x 0.75 litre bottles
- 14 fully extendable shelves with telescopic rails
- 2 temperature zones to allow storage of red and white wines at different temperatures
- 2 temperature zones with individual temperature control from 5°C to 18°C
- Twin halogen spot lights
- Glass door with UV filter

- Removable magnetic door seals
- Right hinged reversible door
- Annual running cost: £37.20
- CFC and HFC free
- Furniture door required**

### Optional accessories:

- Stainless steel door panel (right hinge) CI24Z590, (left hinge) CI24Z690 (Door panel size 202.9H x 90.8W x 1.9D cm)
- Stainless steel door handle CI10Z090
- Stainless steel ventilation grill (right hinge) CI24Z000, (left hinge) CI24Z100
- Installation kit for side by side installation CI60Z000
- Heating kit for installation of appliances with gap between of 0.5 16cm CI60Z100

The line drawings featured are provided as a guide to general dimensions only and are subject to amendment without prior notice. For full dimensional and installation details, please refer to the documentation supplied with the appliance.

# iQ700 aCool fridge freezer combination

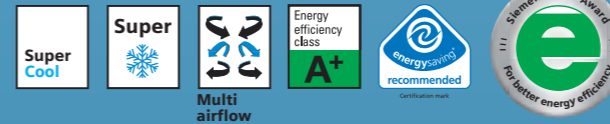
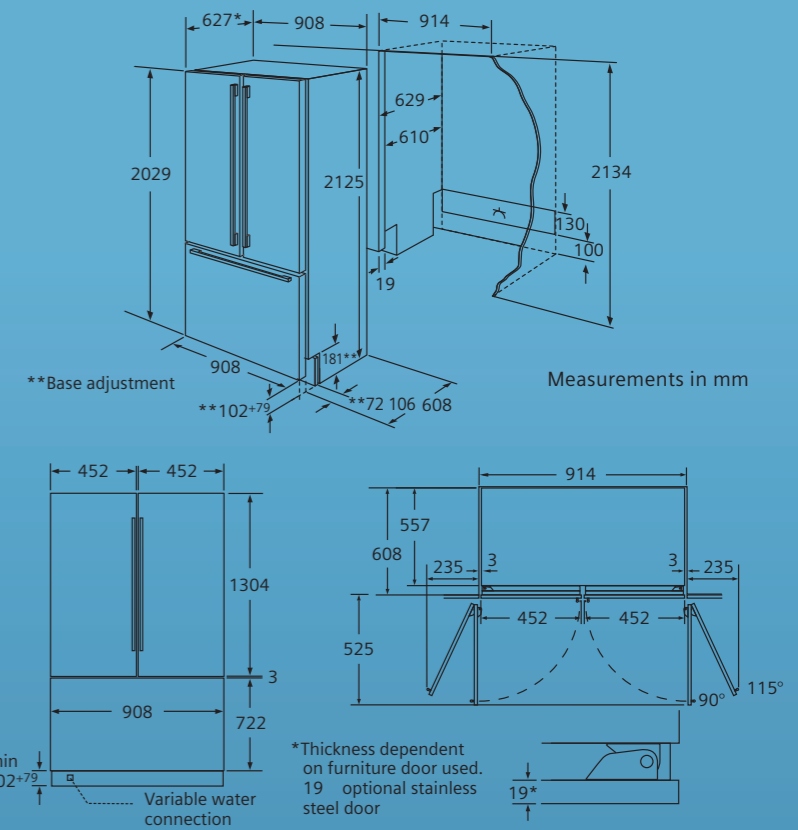

## aCool fridge freezer combination CI36BP00

- Can be combined with other aCool models
- Electronic control with digital temperature display
- Audible alarm system in case of power failure or door left open
- Fridge section gross capacity: 396 litres/14.0 cu.ft
- Motorised height adjustable top shelf, activated at the touch of a button
- Height adjustable safety glass shelves with half shelf facility
- Transparent drawer with fully extendable telescopic rails
- Multi airflow cooling
- Super cool function
- Removable door storage compartments
- Humidity controlled salad drawers with fully extendable telescopic rails
- Twin halogen lights

- Extra deep door tray for optimum storage
- Dairy compartment with magnetic lid for hermetically sealing food
- airFresh filter in fridge
- Freezer section gross capacity: 164 litres/5.8 cu.ft
- Transparent freezer drawers with steel trim
- Pull out freezer drawer with automatic ice cube maker
- Super freeze function
- Removable magnetic door seals
- Right hinged reversible doors
- Annual running cost: £50.40
- CFC and HFC free
- Energy efficiency rating A+
- Furniture door required**

### Optional accessories:

- Stainless steel door panel (set of 3) CI36Z490 (Door panel size 202.9H x 90.8W x 1.9D cm)
- Stainless steel door handle (set of 3) CI10Z490
- Stainless steel ventilation grill CI36Z400
- Installation kit for side by side installation CI60Z000
- Heating kit for installation of appliances with gap between of 0.5 16cm CI60Z100
- Water filter FI50Z000



### Electronic controls

The digital display allows easy navigation through the operating menu and shows the precise temperature. A door status sensor sets off an optical and acoustic warning alarm if the door is left open for any reason. Eco mode can be selected to save energy and there's also a holiday setting.



### Dairy container with lid

This keeps perishable foods sealed so they stay fresher for longer. The lid is sealed magnetically to contain food odours and prevent cross-contamination of food odours.

### Halogen lighting

aCool offers a premium concept in lighting that incorporates spotlights in the ceiling and side mounted halogen strip lights. A halogen light in the roof, side walls and temperature controlled drawer, improves interior visibility and gives brighter, more even light distribution throughout cavity so that food items are more visible on the lower shelves.



### In-door ice water dispenser (FI24DP00)

The in-door ice and water dispenser delivers chilled water, crushed ice and ice cubes (1.9kg of ice cubes in 24 hours) at the touch of a button.



### Integrated ice cube maker (CI36BP00 & FI24NP30)

Positioned inside the freezer drawer, the ice cube maker can produce up to 1.9kg of ice cubes in 24 hours in conveniently sized cubes for all parties and occasions. The storage drawer has room for 1.5kg ice cubes (CI36BP00).

### Wine storage cabinet (CI24WP00)

For professional storage of wines, both white (lower section) and red (upper section), you'll find that this elegant and stylish wine cabinet has room for 98 bottles. It comes fitted with a glass door with UV filter, 14 telescopic storage drawers for maximum accessibility, two independently adjusted temperature zones and electronic temperature control from 5° to 18°C.



Our appliances come packed with the latest **technology and innovations.**



**Precise electronic controls**

All Siemens models feature various types of electronic control to accurately maintain temperature and promote safe food storage in your fridge and freezer. These controls also give different levels of alarm systems to indicate if the freezer door has been left open or if the internal temperature is too high.

**Super cool function**

Adding warm or new food to the fridge can lead to an increase in the internal and food temperatures. By switching on the super cool function before you go shopping ensures the fast and safe cooling of food added to the fridge without affecting the temperature of food already in the fridge.



**Internal krypton light**

The fridge interior is lit by a krypton light – this is a stronger light than used in standard fridges and fully illuminates the fridge, allowing easy viewing of your fridge contents.



**Super freeze function**

Adding warm or new food to the freezer may lead to part defrosting of pre-frozen items. The super freeze function ensures fast and safe freezing of food added to the freezer.



**No more defrosting with our frost free fridge freezers**

Our KA62DV50, KA62DA70, KA62DP90 and KI32NA50 fridge freezers feature frost free technology, which means no more defrosting. This ensures a permanently cold, dry environment with no build up of ice in the freezer. Food packs don't stick together. The labels on the food packs stay clear and easy to read and ice cubes will not stick to the tray. These models now use their electronics to monitor and control the frost free operation, ensuring the freezer only initiates the frost free cycle when the appliance actually needs it, saving considerably in energy consumption.



**airVent shelving**

Vents at the rear of the fridge shelves encourage the natural air movement within the fridge. This increased air circulation reduces hot spots and extends food freshness.



**Deep vegetable drawer**

The deep drawer with its rippled base encourages air movement within the drawer. This reduces the level of humidity and extends food freshness.



When it comes to food storage, **quality and safety** override everything.



**bacteriaKontrol**

There's no hiding place for unwanted organisms in our refrigerators. The internal walls include a natural anti-bacterial system that lasts for the lifetime of the appliance.



**Flat hinged design**

Most models in the range feature a flat hinged door design that enables quick and easy fitment of the furniture door, without the need for extra drilling. This hinge design holds a door weight of up to 45kg, gives an increased door opening angle of 115°, and features automatic door closing at an angle of less than 20°.



**Reasons why you should buy a Siemens cooling appliance.**

Your fridge and freezer probably consume the highest levels of energy in your home. Plugged in for 24 hours a day, 52 weeks a year, keeping them running contributes to the £3bn UK households spend on electricity bills per year. Compared with their counterparts from 1990, today's cooling appliances consume 79% less energy.

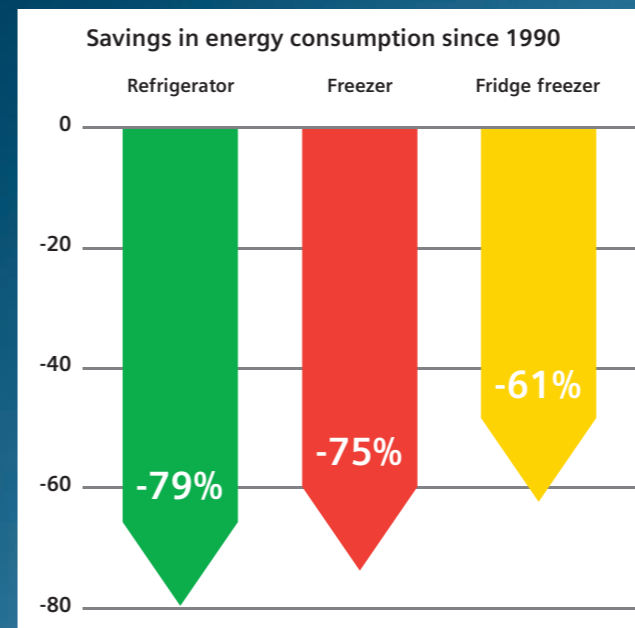

Source: BSH Bosch and Siemens Hausgerate GmbH

**A++ is up to 45% more efficient than A for cooling appliances.**

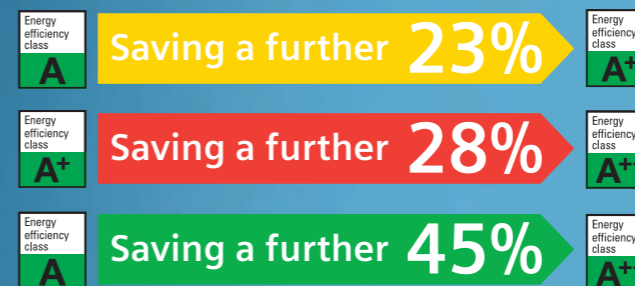

**Environmental pledge**

All Siemens cooling appliances are built using recyclable plastics. And all our models are free from HFCs and CFCs (the gases that cause long-term damage to the ozone layer).

**Tried and tested**

All Siemens fridges and freezers are built to last. And rigorous testing ensures that our products meet all the requirements of our customers.

Every single one of our appliances are tested before they leave the factory. For 24 hours a day, our components are tested continuously to the maximum tolerance possible for the equivalent lifetime of the appliance. The shelves are strong enough to take 20kg of weight and our doors are weighted and then opened and closed by the handle 200,000 times during testing to ensure they are robust. (200,000 times is equivalent to opening and closing the door 27 times per day for 20 years).

Materials are not only tested for suitability and longevity, we also look at how they sound and feel when we use them. Like the satisfying "clunk" of a door closing.

**A+ and A++ energy**

Siemens have always aimed for the lowest possible energy consumption rates for our appliances. The majority of the Siemens cooling range is now A+ energy rated. A+ uses up to 25% less electricity than an A rated appliance. This saves you money and helps the environment too. Even an A++ fridge-freezer (K138SA60), is up to 45% more energy efficient than an A rated appliance.

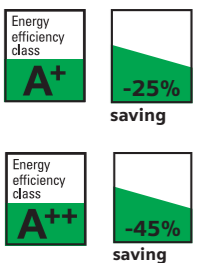

Finally we make sure that, although our products are packed safely for safe transport, we use as little packaging as possible.

# iQ 700 Free-standing coolDuo American fridge freezer

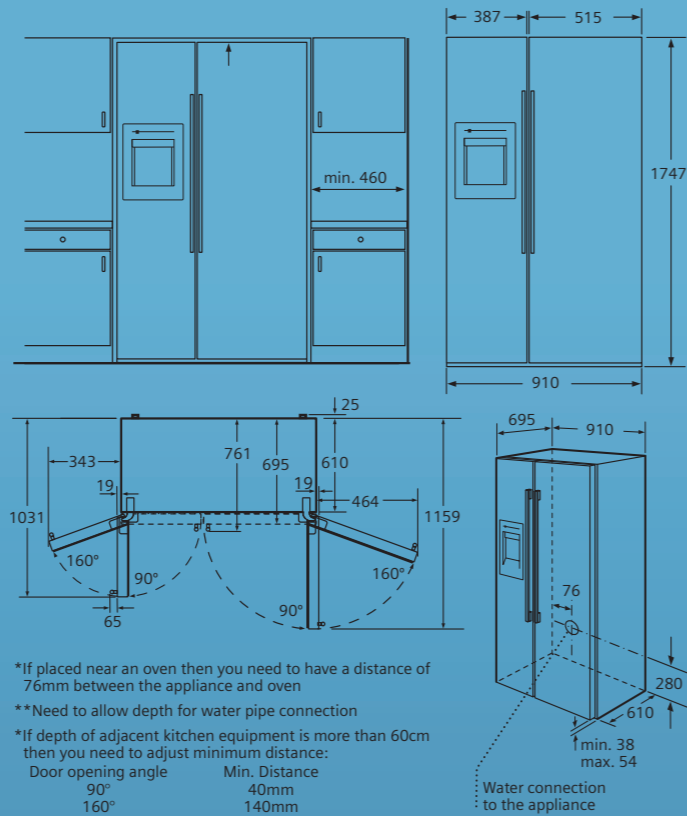

\*If placed near an oven then you need to have a distance of 76mm between the appliance and oven  
 \*\*Need to allow depth for water pipe connection  
 \*If depth of adjacent kitchen equipment is more than 60cm then you need to adjust minimum distance:  
 Door opening angle Min. Distance  
 90° 40mm  
 160° 140mm

Measurements in mm



# iQ 500 Free-standing coolDuo American fridge freezer

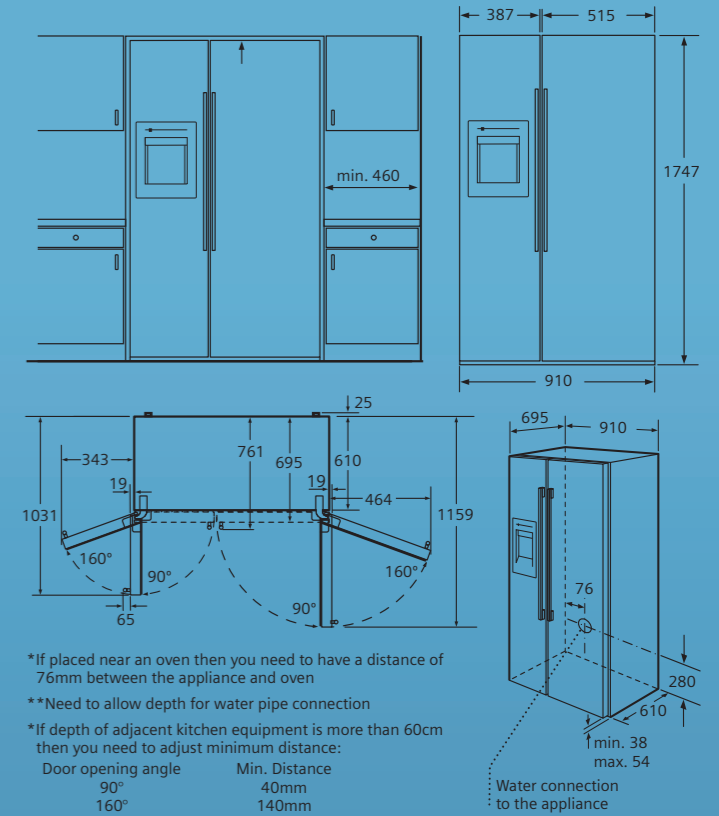

\*If placed near an oven then you need to have a distance of 76mm between the appliance and oven  
 \*\*Need to allow depth for water pipe connection  
 \*If depth of adjacent kitchen equipment is more than 60cm then you need to adjust minimum distance:  
 Door opening angle Min. Distance  
 90° 40mm  
 160° 140mm

Measurements in mm



## Free-standing coolDuo American fridge freezer KA62DP90GB stainless steel

Stainless steel doors and sides

Deli drawer  
 airFresh filter in fridge

Frost free system

Super cool and super freeze function

Visual and audible alarm system

Illuminated dispenser for chilled water, crushed ice or ice cubes

1.0 litre water storage container for water dispenser

Freezer section gross capacity: 200 litres/7.1 cu.ft

2 drawers and 3 safety glass shelves

Door storage compartments

Up to 140 ice cubes produced per day

Water plumbed in (filter supplied)

Internal LED lights

Ice pack storage facility in door

2 ice packs

Twin evaporators so no transference of humidity between fridge and freezer cavity

External LCD electronic controls

Child lock setting on electronic controls

Fridge section gross capacity: 355 litres/12.5 cu.ft

bacteriaKontrol

Height adjustable safety glass shelves (2 adjustable with rotary turning mechanism)

Removable door storage compartments

Full width chrome bottle rack

Electronic temperature controlled chiller compartment with 3 settings (0°C, 2°C or 4°C) for prolonged storage of meat/fish and vegetables

Multi airflow cooling

Interior arc design LED lights

Two doors, left hinge for freezer, right hinged for fridge

Annual running cost: £56.04

CFC and HFC free

Energy efficiency rating A+

Dimensions: 1756 H x 910 W x 695 D mm (761 mm including handle)

Available June 2009



## Free-standing coolDuo American fridge freezer KA62DA70GB stainless steel

Stainless steel doors

Stainless steel coloured sides

Frost free system

Super cool and super freeze function

Visual and audible alarm system

In door dispenser for chilled water, crushed ice or ice cubes

1.0 litre water storage container for water dispenser

Deli drawer

airFresh filter in fridge

Freezer section gross capacity: 200 litres/7.1 cu.ft

2 drawers and 3 safety glass shelves

Door storage compartments

Up to 140 ice cubes produced per day

Water plumbed in (filter supplied)

Bright interior lighting

Ice pack storage facility in door

2 ice packs

Twin evaporators so no transference of humidity between fridge and freezer cavity

External LCD electronic controls

Child lock setting on electronic controls

Fridge section gross capacity: 355 litres/12.5 cu.ft

bacteriaKontrol

Height adjustable safety glass shelves (1 adjustable with rotary turning mechanism)

Removable door storage compartments

Full width chrome bottle rack

Electronic temperature controlled chiller compartment with 3 settings (0°C, 2°C or 4°C) for prolonged storage of meat/fish and vegetables

Multi airflow cooling

Two doors, left hinge for freezer, right hinged for fridge

Annual running cost: £55.80

CFC and HFC free

Energy efficiency rating A+

Dimensions: 1756 H x 910 W x 695 D mm (761 mm including handle)

Available June 2009



The line drawings featured are provided as a guide to general dimensions only and are subject to amendment without prior notice. For full dimensional and installation details, please refer to the documentation supplied with the appliance.



# iQ 300 Free-standing coolDuo American fridge freezer

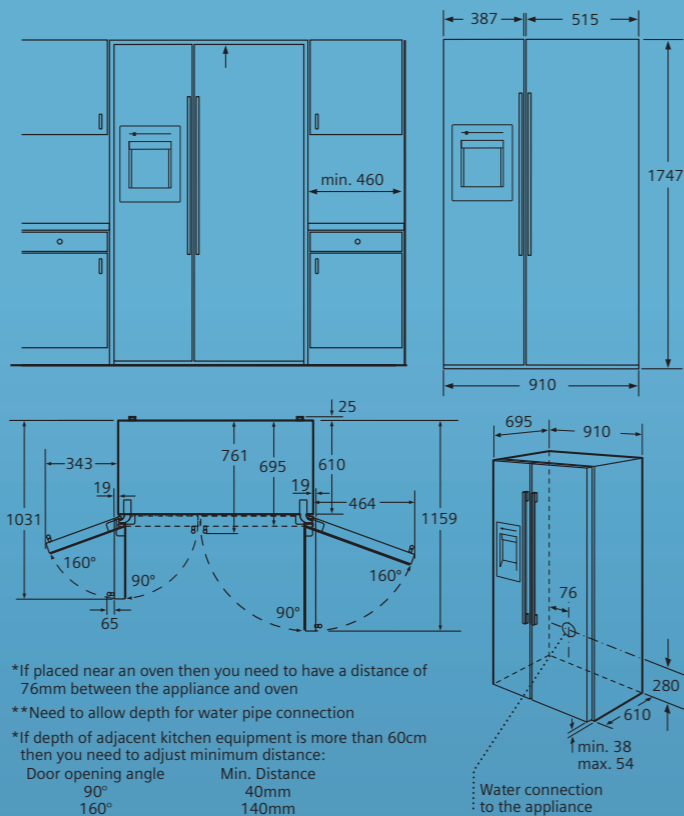

Measurements in mm



## Free-standing coolDuo American fridge freezer KA62DV50GB black

High gloss black finish doors and black sides

Frost free system  
Super cool and super freeze function  
Audible alarm system  
In door dispenser for chilled water, crushed ice or ice cubes  
1.0 litre water storage container for water dispenser

External LED electronic controls

Fridge section gross capacity:  
378 litres/13.4 cu.ft

bacteriaKontrol  
Height adjustable safety glass shelves  
Removable door storage compartments  
Multi airflow cooling  
Deli drawer

Freezer section gross capacity:  
213 litres/7.5 cu.ft

2 drawers and 3 safety glass shelves  
Door storage compartments  
Up to 140 ice cubes produced per day  
Water plumbed in (filter supplied)  
Internal light  
Twin evaporators so no transference of humidity between fridge and freezer cavity

Two doors, left hinge for freezer, right hinged for fridge

Annual running cost: £66.84

CFC and HFC free  
Energy efficiency rating A  
Dimensions: 1756 H x 910 W x 695 D mm (761 mm including handle)

Available July 2009

The line drawings featured are provided as a guide to general dimensions only and are subject to amendment without prior notice. For full dimensional and installation details, please refer to the documentation supplied with the appliance.

# iQ 500 Built-in frost free fridge freezer

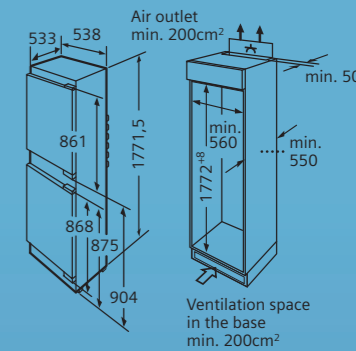

Measurements in mm

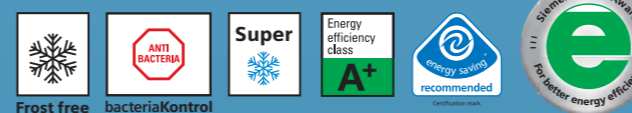
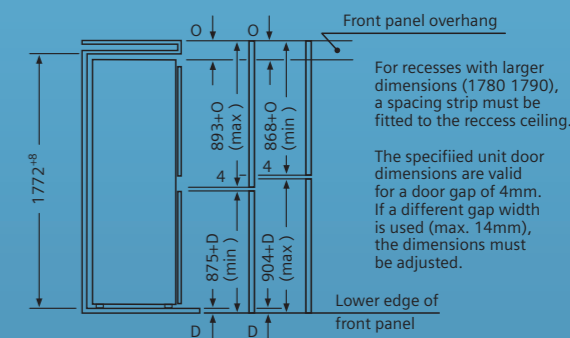

## Built-in frost free fridge freezer KI32NA50GB

Frost free system  
Electronic interior display  
Independent fridge and freezer temperature control

Fridge section gross capacity:  
152 litres/5.4 cu.ft

bacteriaKontrol  
Height adjustable safety glass shelves with half shelf facility  
Foamed in evaporator  
Deluxe removable door storage compartments  
Pull out fridge tray  
Humidity controlled salad drawers

Freezer section gross capacity:  
110 litres/3.9 cu.ft

Super freeze function  
Transparent freezer drawers  
Visual and acoustic alarm system

Automatic door closing >20°  
Flat hinge design  
Removable magnetic door seal  
Right hinged reversible doors

Annual running cost: £36.00  
CFC and HFC free  
Energy efficiency rating A+

Furniture doors required

# iQ 300 Built-in fridge freezer

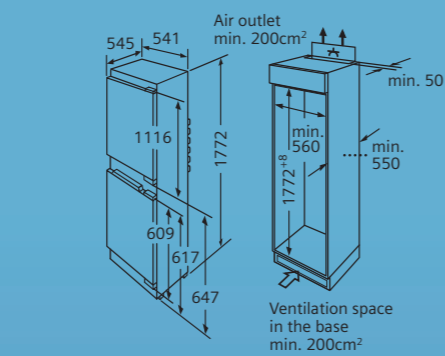

Measurements in mm

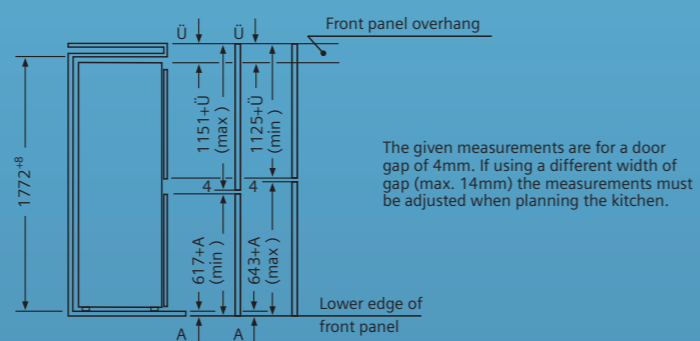

## Built-in fridge freezer KI38SA60 white

Electronic interior display  
Independent fridge and freezer temperature control

Fridge section gross capacity: 224 litres/7.9 cu.ft  
**bacteriaKontrol**  
Height adjustable safety glass shelves  
Foamed in evaporator  
Deluxe removable door storage compartments  
Pull out fridge tray  
Krypton interior light

Freezer section gross capacity: 72 litres/2.5 cu.ft  
Super freeze function  
Transparent freezer drawers  
Acoustic alarm system

Automatic door closing > 20°  
Flat hinge design  
Removable magnetic door seal  
Right hinged reversible doors

Annual running cost £25.20  
CFC and HFC free  
Energy efficiency rating A++

**Furniture doors required**

The line drawings featured are provided as a guide to general dimensions only and are subject to amendment without prior notice. For full dimensional and installation details, please refer to the documentation supplied with the appliance.

# iQ 300 Built-in fridge freezer

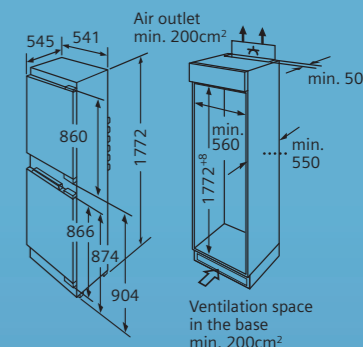

Measurements in mm

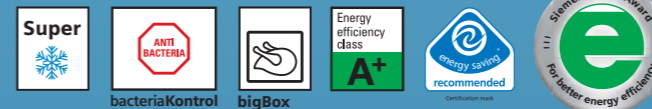
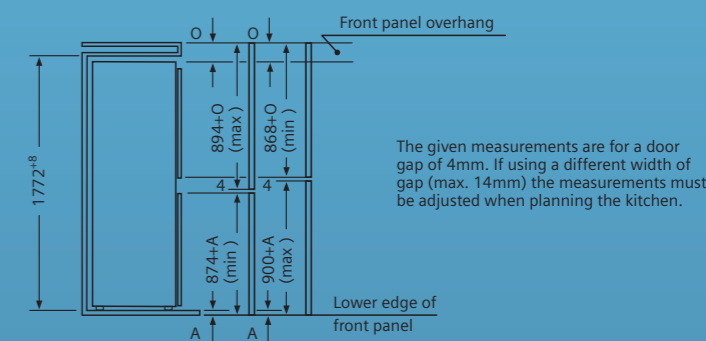

## Built-in fridge freezer KI32VA50GB

Electronically regulated LED control panel

Fridge section gross capacity: 170 litres/6 cu.ft  
**bacteriaKontrol**  
airVent shelving system  
Height adjustable safety glass shelves  
Foamed in evaporator  
Deluxe removable door storage compartments  
Pull out fridge tray  
Humidity controlled salad drawer with rippled base

Freezer section gross capacity: 106 litres/3.7 cu.ft  
Super freeze function  
Transparent freezer drawers  
'Big box' freezer drawer

Automatic door closing >20°  
Flat hinge design  
Removable magnetic door seal  
Right hinged reversible doors

Annual running cost: £34.56  
CFC and HFC free  
Energy efficiency rating A+

**Furniture doors required**

# iQ 300 Built-in fridge freezer

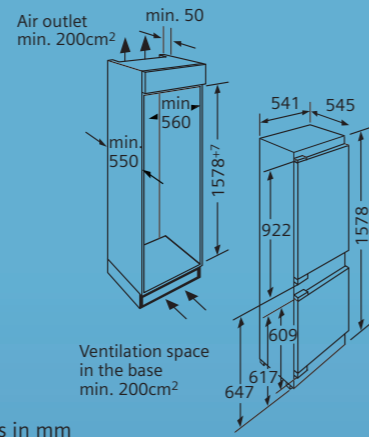

Measurements in mm

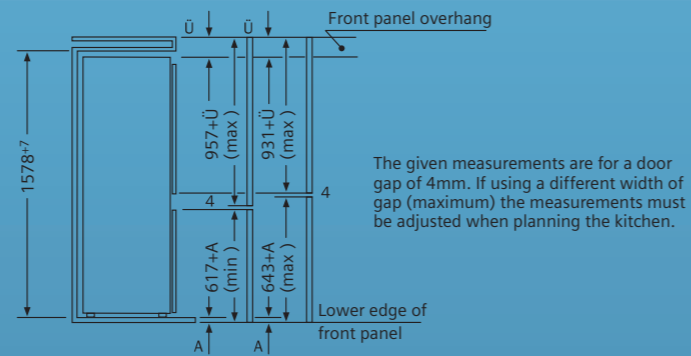

## Built-in fridge freezer KI28VA40GB

Electronically regulated LED control panel

Fridge section gross capacity:  
183 litres/6.5 cu.ft

bacteriaKontrol

airVent shelving system

Height adjustable safety glass shelves

Foamed in evaporator

Deluxe removable door storage  
compartments

Pull out fridge tray

Humidity controlled salad drawer with  
rippled base

Freezer section gross capacity:  
72 litres/2.5 cu.ft

Super freeze function

Transparent freezer drawers

'Big box' freezer drawer

Automatic door closing >20°

Flat hinge design

Removable magnetic door seal

Right hinged reversible doors

Annual running cost: £36.12

CFC and HFC free

Energy efficiency rating A

**Furniture doors required**

The line drawings featured are provided as a guide to general dimensions only and are subject to amendment without prior notice.  
For full dimensional and installation details, please refer to the documentation supplied with the appliance.

# iQ 300 Built-in fridge freezer

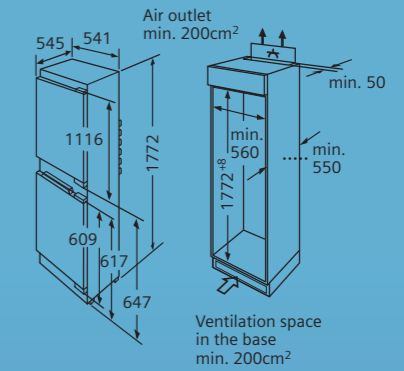

Measurements in mm

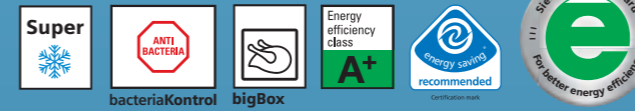
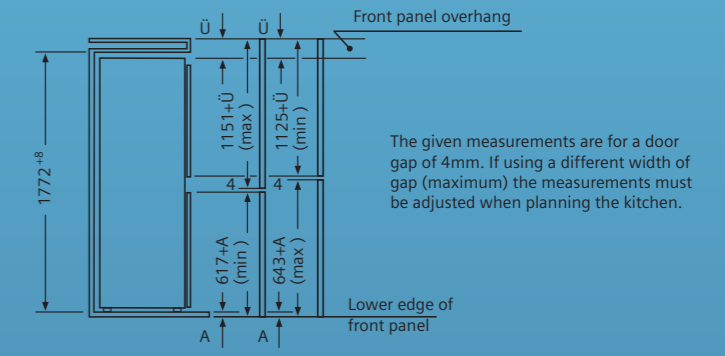

## Built-in fridge freezer KI38VA50GB

Electronically regulated LED control panel

Fridge section gross capacity:  
224 litres/7.9 cu.ft

bacteriaKontrol

airVent shelving system

Height adjustable safety glass shelves

Foamed in evaporator

Deluxe removable door storage  
compartments

Pull out fridge tray

Humidity controlled salad drawer with  
rippled base

Freezer section gross capacity:  
72 litres/2.2 cu.ft

Super freeze function

Transparent freezer drawers

'Big box' freezer drawer

Automatic door closing >20°

Flat hinge design

Removable magnetic door seal

Right hinged reversible doors

Annual running cost: £33.60

CFC and HFC free

Energy efficiency rating A+

**Furniture doors required**

# iQ 100 Built-in fridge freezer

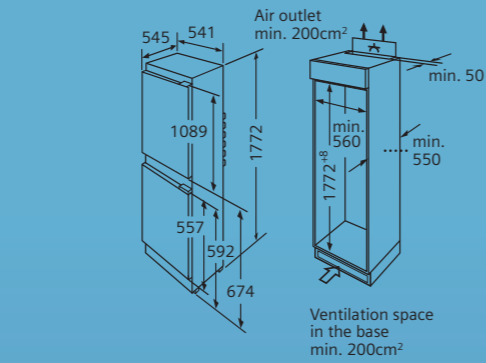

Measurements in mm

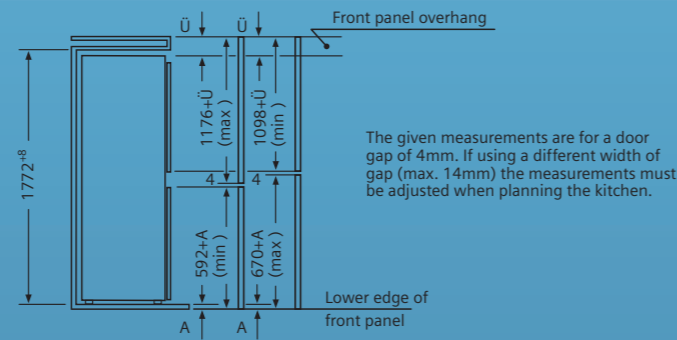

## Built-in fridge freezer KI38VV20GB

Fridge section gross capacity:  
222 litres/7.8 cu.ft

- bacteriaKontrol
- airVent shelving system
- Height adjustable safety glass shelves
- Foamed in evaporator
- Removable door storage compartments
- Humidity controlled salad drawer with rippled base

Freezer section gross capacity:

- 72 litres/2.5 cu.ft
- Transparent freezer drawers
- 'Big box' freezer drawer

- Sliding hinge design
- Removable magnetic door seal

- Right hinged reversible doors
- Annual running cost: £33.60
- CFC and HFC free
- Energy efficiency rating A+

### Furniture doors required

The line drawings featured are provided as a guide to general dimensions only and are subject to amendment without prior notice. For full dimensional and installation details, please refer to the documentation supplied with the appliance.

# iQ 100 Built-in fridge freezer

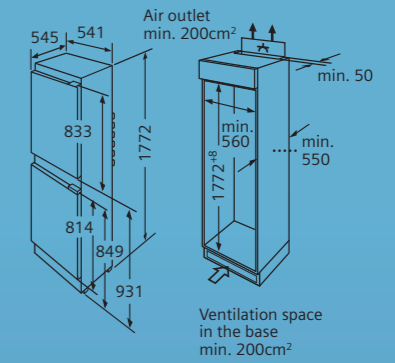

Ventilation space in the base min. 200cm²

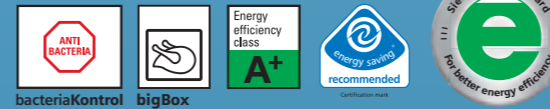
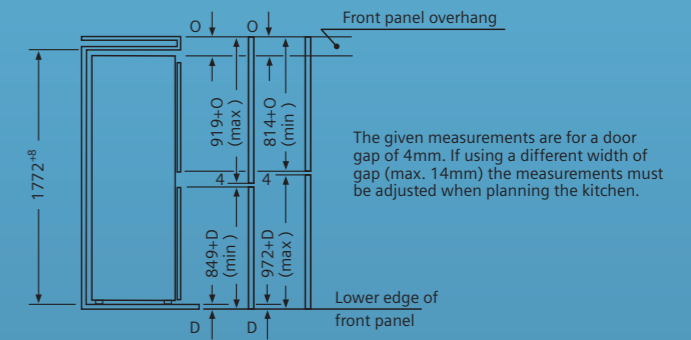

## Built-in fridge freezer KI32VV20GB

Fridge section gross capacity:  
168 litres/5.9 cu.ft

- bacteriaKontrol
- airVent shelving system
- Height adjustable safety glass shelves
- Foamed in evaporator
- Removable door storage compartments
- Humidity controlled salad drawer with rippled base

Freezer section gross capacity:

- 106 litres/3.7 cu.ft
- Transparent freezer drawers
- 'Big box' freezer drawer

- Sliding hinge design
- Removable magnetic door seal

- Right hinged reversible doors
- Annual running cost: £34.56
- CFC and HFC free
- Energy efficiency rating A+

### Furniture doors required

# iQ 300 Built-in wineKooler

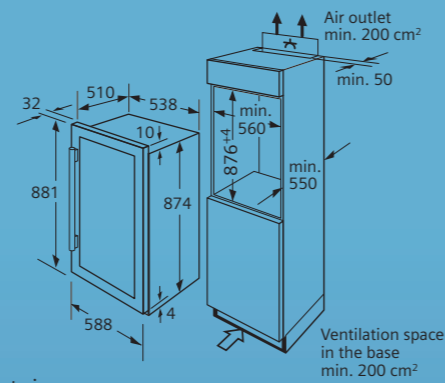

Measurements in mm



## Built-in wine eKooler KF18WA40GB

UV protected tinted glass door supplied with stainless steel handle  
Interior light activated by touch sensitive handle  
Light dimming function

Electronically regulated LED control panel  
Super cool function

Cooler gross capacity: 153 litres/5.4 cu.ft  
Holds 32 bottles of wine  
bacteriaKontrol

Four shelves with contoured bottle racks for vibration free storage

One flat glass shelf for small bottles or party food

Foamed in evaporator  
Adjustable temperature from 6°C 14°C  
Interior light  
Removable magnetic door seal  
**Right hinged door only**

Annual running cost: £17.52  
CFC and HFC free

The line drawings featured are provided as a guide to general dimensions only and are subject to amendment without prior notice. For full dimensional and installation details, please refer to the documentation supplied with the appliance.

# iQ 500 Built-in refrigerator

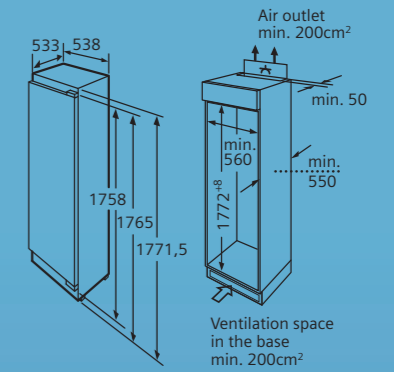

Measurements in mm

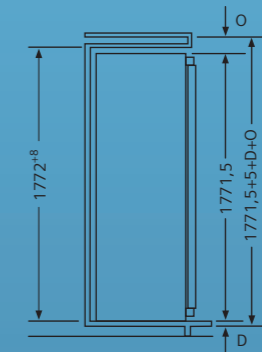

For recesses with larger dimensions (1780 1790), a strip must be fitted to the recess ceiling to compensate: this can also be ordered in the form of white plastic strip using spare part product code 438172.



## Built-in refrigerator K138LA50GB

Electronically regulated LED control panel  
Super cool function

Fridge section gross capacity: 253 litres/8.9 cu.ft

bacteriaKontrol

Height adjustable safety glass shelves with half shelf facility

Foamed in evaporator

Deluxe removable door storage compartments

Pull out fridge tray

Humidity controlled salad drawers

Freezer section gross capacity: 36 litres/1.3 cu.ft

Super freeze function

Door closed indicator

Automatic door closing >20°

Flat hinge design

Removable magnetic door seal

Right hinged reversible door

Annual running cost: £31.08

CFC and HFC free

Energy efficiency rating A+

**Furniture door required**

# iQ300 Built-in larder fridge

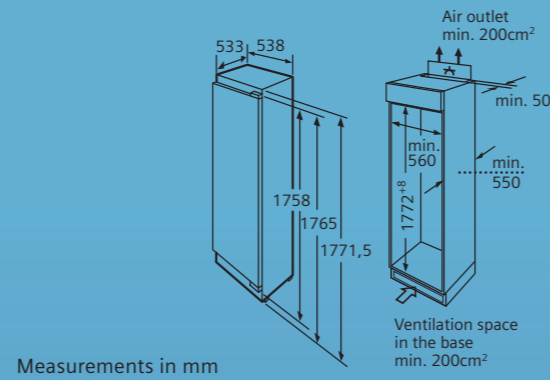

Measurements in mm

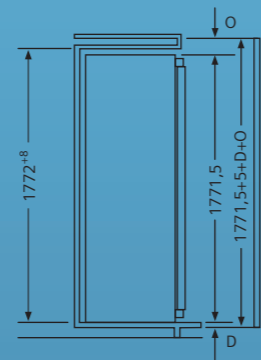

For recesses with larger dimensions (1780 1790), a strip must be fitted to the recess ceiling to compensate: this can also be ordered in the form of white plastic strip using spare part product code 438172.



## Built-in larder fridge KI38RA50GB

Electronically regulated LED control panel  
Super cool function

Fridge section gross capacity:  
312 litres/11 cu.ft

bacteriaKontrol  
Internal fridge fan for even cooling  
Height adjustable safety glass shelves with half shelf facility  
Foamed in evaporator  
Deluxe removable door storage compartments  
Pull out fridge tray  
Humidity controlled salad drawers

Automatic door closing >20°  
Flat hinge design  
Removable magnetic door seal  
Right hinged reversible door  
  
Annual running cost: £17.04  
CFC and HFC free  
Energy efficiency A+

**Furniture door required**

The line drawings featured are provided as a guide to general dimensions only and are subject to amendment without prior notice. For full dimensional and installation details, please refer to the documentation supplied with the appliance.

# iQ300 Built-in larder fridge

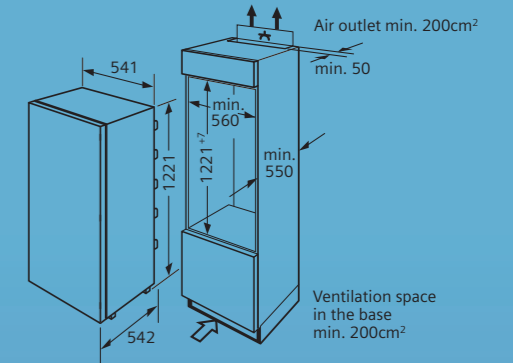

Measurements in mm

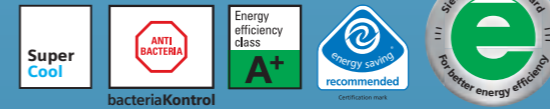

## Built-in larder fridge KI24RA50GB

Electronically regulated LED control panel  
Super cool function

Fridge section gross capacity:  
228 litres/8 cu.ft

bacteriaKontrol  
airVent shelving system  
Height adjustable safety glass shelves  
Foamed in evaporator  
Deluxe removable door storage compartments  
Pull out fridge tray  
Humidity controlled salad drawer with rippled base

Automatic door closing >20°  
Flat hinge design  
Removable magnetic door seal  
Right hinged reversible door  
  
Annual running cost: £15.72  
CFC and HFC free  
Energy efficiency rating A+

**Furniture door required**

## iQ300 Built-in larder fridge

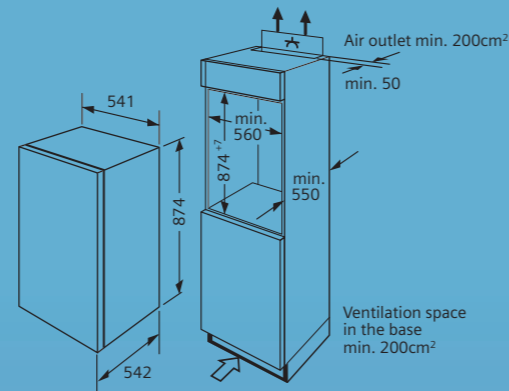

Measurements in mm



### Built-in larder fridge KI18RA50GB

Electronically regulated LED control panel  
Super cool function

Fridge section gross capacity:  
155 litres/5.5 cu.ft

bacteriaKontrol

airVent shelving system

Height adjustable safety glass shelves

Foamed in evaporator

Deluxe removable door storage  
compartments

Pull out fridge tray

Humidity controlled salad drawer  
with rippled base

Automatic door closing >20°

Flat hinge design

Removable magnetic door seal

Right hinged reversible door

Can be combined with matching freezer  
GI18DA50GB

Annual running cost: £14.64

CFC and HFC free

Energy efficiency rating A+

**Furniture door required**

The line drawings featured are provided as a guide to general dimensions only and are subject to amendment without prior notice.  
For full dimensional and installation details, please refer to the documentation supplied with the appliance.

## iQ300 Built-in freezer

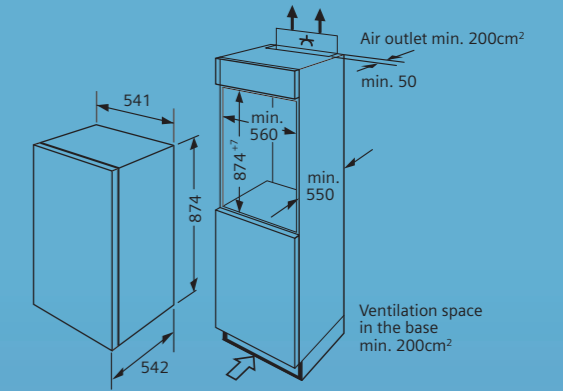

Measurements in mm



### Built-in freezer GI18DA50GB

Super freeze function

Freezer section gross capacity:  
106 litres/3.7 cu.ft

Transparent freezer drawers

Soft fruit freezing tray

Visual and audible alarm system

Automatic door closing >20°

Flat hinge design

Removable magnetic door seal

Right hinged reversible door

Can be combined with matching fridge  
KI18RA50GB

Annual running cost: £23.28

CFC and HFC free

Energy efficiency rating A+

**Furniture door required**

## iQ 100 Built-under refrigerator

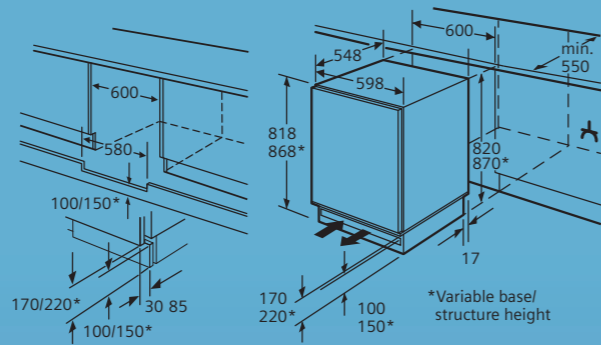

Space for electrical connection next to the appliance on the left or right hand side. Ventilation in the base.

Measurements in mm



### Built-under refrigerator KU15LA50GB

Fridge section gross capacity:  
116 litres/4.1 cu.ft

**bacteriaKontrol**

Height adjustable safety glass shelves  
with half shelf facility

Two piece sliding shelf above recessed  
salad drawer

Foamed in evaporator

Removable door storage compartments

Automatic door closing >20°

Flat hinge design

Removable magnetic door seal

Right hinged reversible door

Annual running cost: £20.76

CFC and HFC free

Energy efficiency rating A+

**Furniture door required**

Freezer section gross capacity:  
15 litres/0.5 cu.ft

The line drawings featured are provided as a guide to general dimensions only and are subject to amendment without prior notice. For full dimensional and installation details, please refer to the documentation supplied with the appliance.

## iQ 100 Built-under larger fridge and freezer

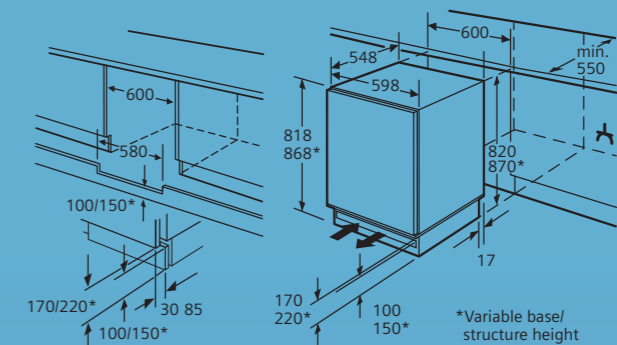

Space for electrical connection next to the appliance on the left or right hand side. Ventilation in the base.

Measurements in mm



### Built-under larger fridge KU15RA50GB

Fridge section gross capacity:  
142 litres/5.2 cu.ft

**bacteriaKontrol**

Height adjustable safety glass shelves  
with half shelf facility

Two piece sliding shelf above recessed  
salad drawer

Foamed in evaporator

Removable door storage compartments

Automatic door closing >20°

Flat hinge design

Removable magnetic door seal

Right hinged reversible door

Can be combined side by side with matching  
freezer GU15DA40GB

Annual running cost: £14.16

CFC and HFC free

Energy efficiency rating A+

**Furniture door required**

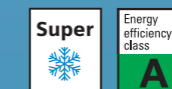

### Built-under freezer GU15DA40GB

Freezer section gross capacity:  
114 litres/4.1 cu.ft

**Super freeze function**

Transparent freezer drawers

Additional storage in plinth recess

Interior door temperature gauge

Visual and audible alarm system

Automatic door closing >20°

Flat hinge design

Removable magnetic door seal

Right hinged reversible door

Can be combined side by side with matching  
fridge KU15RA50GB

Annual running cost: £25.32

CFC and HFC free

Energy efficiency rating A

**Furniture door required**



# iQ700 aCool fridge

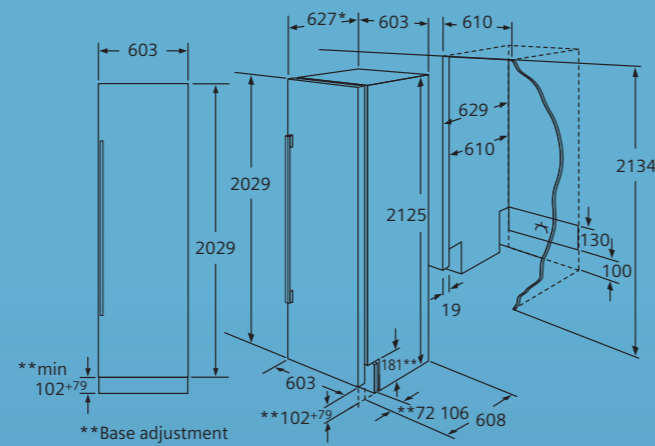

Measurements in mm

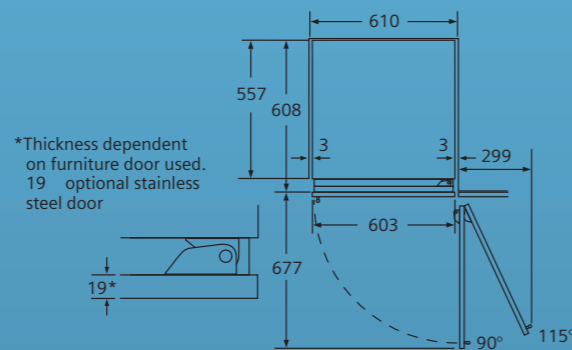

\*Thickness dependent on furniture door used. 19 optional stainless steel door

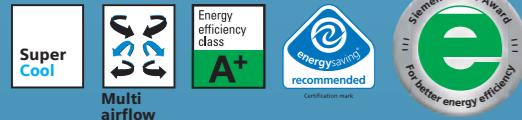

## aCool fridge CI24RP00

Can be combined with other aCool models  
Electronic control with digital temperature display  
Audible alarm system in case of power failure or door left open

Fridge section gross capacity: 381 litres/13.5 cu.ft

Motorised height adjustable top shelf, activated at the touch of a button  
Height adjustable safety glass shelves  
Transparent drawer with fully extendable telescopic rails  
Multi airflow cooling  
Super cool function

Removable door storage compartments  
Humidity controlled salad drawer with fully extendable telescopic rails

Twin halogen spot lights  
Extra deep door tray for optimum storage  
Dairy compartment with magnetic lid for hermetically sealing food  
airFresh filter in fridge  
Electronically controlled freshProtect box with 3 temperature settings 0°C, 1.5°C or 3°C

Removable magnetic door seals  
Right hinged reversible doors

Annual running cost: £20.16  
CFC and HFC free  
Energy efficiency rating A+

**Furniture door required**

### Optional accessories:

Stainless steel door panel FI24Z090 (Door panel size 202.9H x 60.3W x 1.9D cm)  
Stainless steel door handle CI10Z090  
Stainless steel ventilation grill (right hinge) CI24Z000, (left hinge) CI24Z100  
Installation kit for side by side installation CI60Z000  
Heating kit for installation of appliances with gap between of 0.5 16cm CI60Z100

The line drawings featured are provided as a guide to general dimensions only and are subject to amendment without prior notice. For full dimensional and installation details, please refer to the documentation supplied with the appliance.

# iQ700 aCool fridge

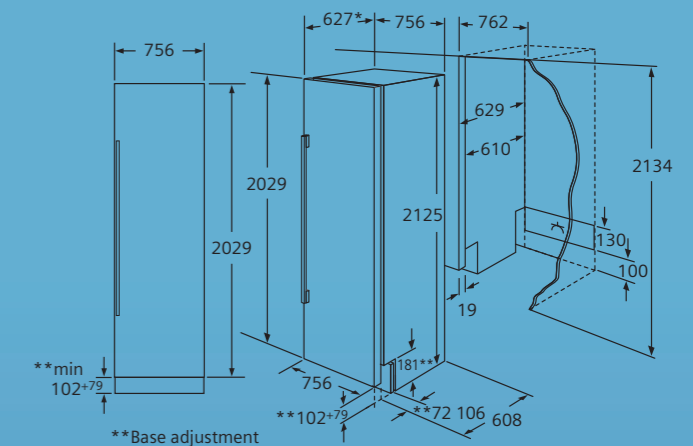

Measurements in mm

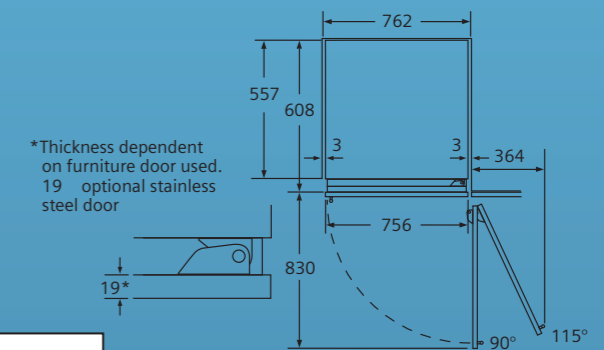

\*Thickness dependent on furniture door used. 19 optional stainless steel door



## aCool fridge CI30RP00

Can be combined with other aCool models  
Electronic control with digital temperature display  
Audible alarm system in case of power failure or door left open

Fridge section gross capacity: 496 litres/17.5 cu.ft

Motorised height adjustable top shelf, activated at the touch of a button  
Height adjustable safety glass shelves  
Transparent drawer with fully extendable telescopic rails  
Multi airflow cooling  
Super cool function

Removable door storage compartments  
Humidity controlled salad drawer with fully extendable telescopic rails

Twin halogen spot lights  
Extra deep door tray for optimum storage  
Dairy compartment with magnetic lid for hermetically sealing food  
airFresh filter in fridge  
Electronically controlled freshProtect box with 3 temperature settings 0°C, 1.5°C or 3°C

Removable magnetic door seals  
Right hinged reversible doors

Annual running cost: £21.72  
CFC and HFC free  
Energy efficiency rating A+

**Furniture door required**

### Optional accessories:

Stainless steel door panel FI30Z090 (Door panel size 202.9H x 75.6W x 1.9D cm)  
Stainless steel door handle CI10Z090  
Stainless steel ventilation grill (right hinge) CI30Z000, (left hinge) CI30Z100  
Installation kit for side by side installation CI60Z000  
Heating kit for installation of appliances with gap between of 0.5 16cm CI60Z100



# iQ700 aCool frost free freezer with ice and water dispenser

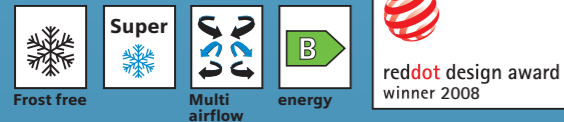
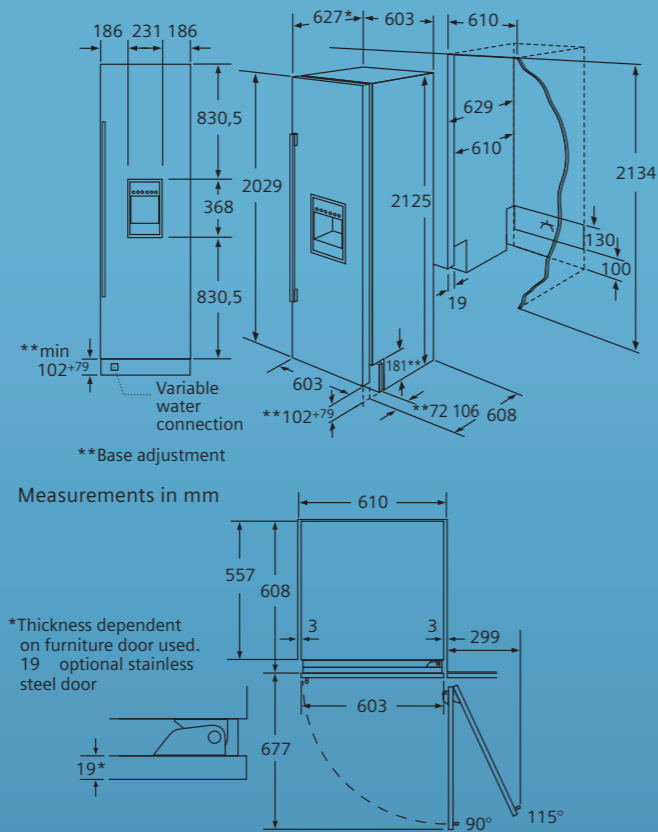

# iQ700 aCool frost free freezer with ice maker

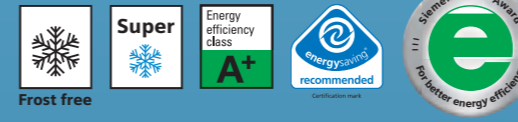
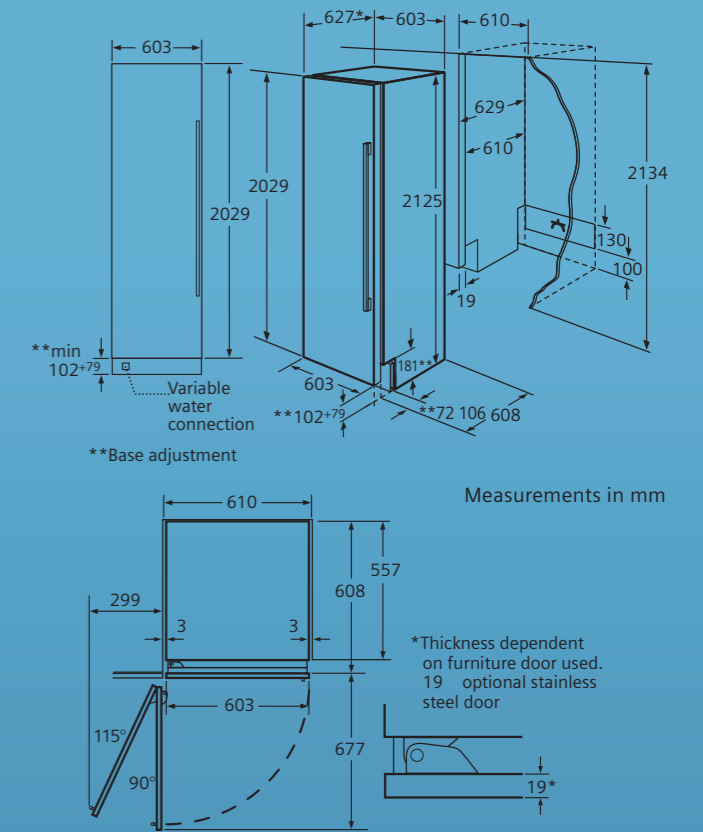

## aCool frost free freezer with ice and water dispenser FI24DP00

Can be combined with other aCool models  
Electronic control with digital temperature display  
Audible and optical alarm system in case of power failure or door left open  
Frost free  
  
Freezer section gross capacity: 320 litres/11.3 cu.ft  
Height adjustable metal shelves  
Transparent drawers with fully extendable telescopic rails  
Multi airflow system  
Super freeze function

In door dispenser for chilled water, crushed ice and ice cubes: produces 127 ice cubes in 24 hours  
  
Removable magnetic door seals  
Right hinged door only

Annual running cost: £45.96  
CFC and HFC free  
Energy efficiency rating B

**Furniture door required**

2 door removable door compartments, one with lid  
Twin halogen spot lights

### Optional accessories:

Stainless steel door panel FI24Z290 (Door panel sizes 202.9H x 60.3W x 1.9D cm)  
Stainless steel door handle CI10Z090  
Stainless steel ventilation grill (right hinge) FI24Z200  
Installation kit for side by side installation CI60Z000  
Heating kit for installation of appliances with gap between of 0.5 16cm CI60Z100  
Water filter FI50Z000

The line drawings featured are provided as a guide to general dimensions only and are subject to amendment without prior notice. For full dimensional and installation details, please refer to the documentation supplied with the appliance.

## aCool frost free freezer with ice maker FI24NP30

Can be combined with other aCool models  
Electronic control with digital temperature display  
Audible alarm system in case of power failure or door left open  
Frost free  
  
Freezer section gross capacity: 340 litres/12.0 cu.ft  
Height adjustable metal shelves  
Transparent drawers with fully extendable telescopic rails  
Multi airflow system  
Super freeze function

Removable door compartments  
Twin halogen spot lights  
Integrated automatic ice cube maker produces 86 ice cubes in 24 hours  
  
Removable magnetic door seals  
Right hinged reversible doors

Annual running cost: £42.24  
CFC and HFC free  
Energy efficiency rating A+

**Furniture door required**

### Optional accessories:

Stainless steel door panel FI24Z090 (Door panel sizes 202.9H x 60.3W x 1.9D cm)  
Stainless steel door handle CI10Z090  
Stainless steel ventilation grill (right hinge) FI24Z000, (left hinge) FI24100  
Installation kit for side by side installation CI60Z000  
Heating kit for installation of appliances with gap between of 0.5 16cm CI60Z100  
Water filter FI50Z000

# iQ700 aCool wineKooler

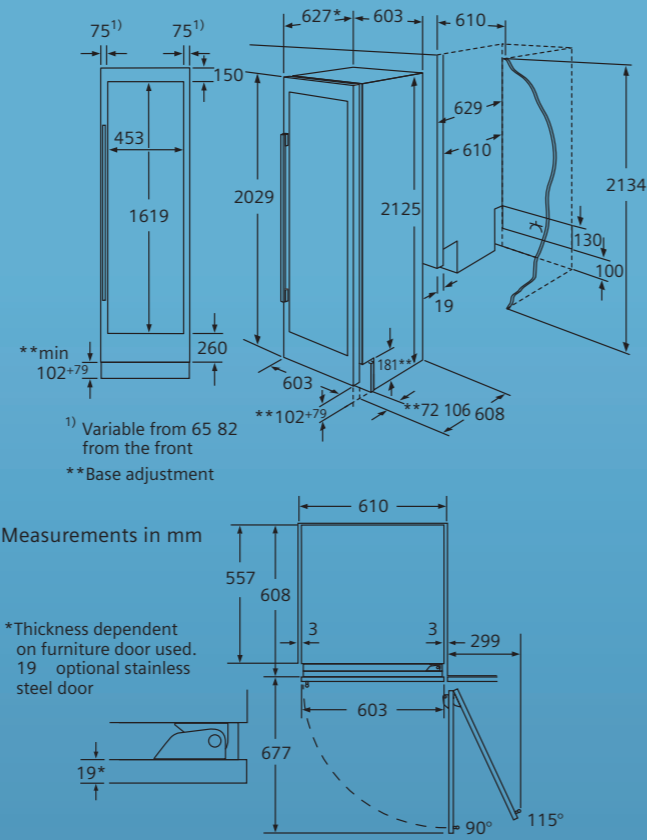

## aCool wineKooler CI24WP00

- Can be combined with other aCool models
- Electronic control with digital temperature display
- Audible alarm system in case of power failure or door left open
- Fridge section gross capacity: 394 litres/13.9 cu.ft
- Storage capacity for up to 98 x 0.75 litre bottles
- 14 fully extendable shelves with telescopic rails
- 2 temperature zones to allow storage of red and white wines at different temperatures
- 2 temperature zones with individual temperature control from 5°C to 18°C
- Twin halogen spot lights
- Glass door with UV filter

- Removable magnetic door seals
- Right hinged reversible door
- Annual running cost: £37.20
- CFC and HFC free
- Furniture door required**

### Optional accessories:

- Stainless steel door panel (right hinge) CI24Z590, (left hinge) CI24Z690
- Stainless steel door handle CI10Z090
- Stainless steel ventilation grill (right hinge) CI24Z000, (left hinge) CI24Z100
- Installation kit for side by side installation CI60Z000
- Heating kit for installation of appliances with gap between of 0.5 16cm CI60Z100

The line drawings featured are provided as a guide to general dimensions only and are subject to amendment without prior notice. For full dimensional and installation details, please refer to the documentation supplied with the appliance.

# iQ700 aCool fridge freezer combination

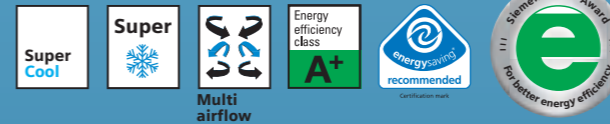
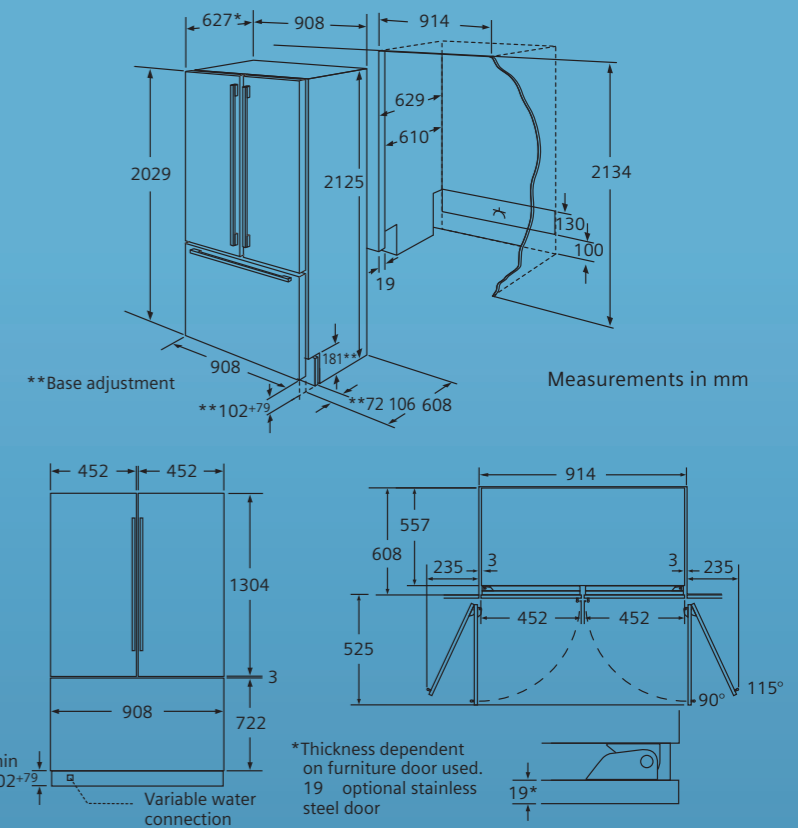

## aCool fridge freezer combination CI36BP00

- Can be combined with other aCool models
- Electronic control with digital temperature display
- Audible alarm system in case of power failure or door left open
- Fridge section gross capacity: 396 litres/14.0 cu.ft
- Motorised height adjustable top shelf, activated at the touch of a button
- Height adjustable safety glass shelves with half shelf facility
- Transparent drawer with fully extendable telescopic rails
- Multi airflow cooling
- Super cool function
- Removable door storage compartments
- Humidity controlled salad drawers with fully extendable telescopic rails
- Twin halogen lights

- Extra deep door tray for optimum storage
- Dairy compartment with magnetic lid for hermetically sealing food
- airFresh filter in fridge
- Freezer section gross capacity: 164 litres/5.8 cu.ft
- Transparent freezer drawers with steel trim
- Pull out freezer drawer with automatic ice cube maker
- Super freeze function

- Removable magnetic door seals
- Right hinged reversible doors
- Annual running cost: £50.40
- CFC and HFC free
- Energy efficiency rating A+

### Furniture door required

### Optional accessories:

- Stainless steel door panel (set of 3) CI36Z490 (Door panel size 202.9H x 90.8W x 1.9D cm)
- Stainless steel door handle (set of 3) CI10Z490
- Stainless steel ventilation grill CI36Z400
- Installation kit for side by side installation CI60Z000
- Heating kit for installation of appliances with gap between of 0.5 16cm CI60Z100
- Water filter FI50Z000



# Product specifications for built-in refrigeration



# Product specifications for built-in refrigeration



Appliance type	Free-standing			Built-in								wineKooler	Built-in					Built-under			aCool					
	American	American	American	Fridge/Freezer	Fridge/Freezer	Fridge/Freezer	Fridge/Freezer	Fridge/Freezer	Fridge/Freezer	Fridge/Freezer	Fridge/Freezer	wineKooler	Fridge	Fridge	Fridge	Fridge	Freezer	Fridge	Fridge	Freezer	Fridge	Fridge	Freezer with integrated ice water dispenser	Freezer with integrated ice maker	wineKooler	Fridge/freezer combination
Design family	iQ 700	iQ 500	iQ 300	iQ 500	iQ 300	iQ 300	iQ 300	iQ 300	iQ 100	iQ 100	iQ 300		iQ 500	iQ 300	iQ 300	iQ 300	iQ 300	iQ 100	iQ 100	iQ 100	iQ 700	iQ 700	iQ 700	iQ 700	iQ 700	iQ 700
Model number	KA62DP90GB	KA62DA70GB	KA62DV50GB	KI32NA50GB	KI38SA60	KI32VA50GB	KI28VA40GB	KI38VA50GB	KI38VV20GB	KI32VV20GB	KF18WA40GB		KI38LA50GB	KI38RA50GB	KI24RA50GB	KI18RA50GB	GI18DA50GB	KU15LA50GB	KU15RA50GB	GU15DA40GB	CI24RP00	CI30RP00	FI24DP00	FI24NP30	CI24WP00	CI36BP00
Description				Right/reversible	Right/reversible	Right/reversible	Right/reversible	Right/reversible	Right/reversible	Right/reversible	Right		Right/reversible	Right/reversible	Right/reversible	Right/reversible	Right/reversible	Right/reversible	Right/reversible	Right/reversible	Right/reversible	Right	Left/reversible	Right/reversible	Right/reversible	
Door hinging				Flat	Flat	Flat	Flat	Flat	Sliding	Sliding	Flat		Flat	Flat	Flat	Flat	Flat	Flat	Flat	Flat	Flat	Flat	Flat	Flat	Flat	Flat
Hinge type																										
Electronic temperature control	•	•	•	•	•	•	•	•	•	•	•		•	•	•	•	•	•	•	•	•	•	•	•	•	•
Appliance dimensions																										
Height	mm	1756	1756	1756	1772	1772	1772	1578	1772	1772	1772	874	1772	1772	1221	874	874	820	820	820	2125	2125	2125	2125	2125	2125
Width	mm	910	910	910	538	541	541	541	541	541	541	538	538	538	541	541	541	598	598	598	603	756	603	603	603	908
Depth	mm	761	761	761	533	545	545	545	545	545	545	542	533	533	542	542	542	548	548	548	608	608	608	608	608	608
Capacities																										
Total gross capacity	litres	570	570	616	262	296	276	255	296	294	274	153	289	312	228	155	106	131	142	114	381	496	320	340	394	560
Total net capacity	litres	533	533	556	233	285	264	244	285	282	263	149	282	308	226	153	98	125	141	98	365	477	298	320	394	530
Refrigerator gross capacity	litres	355	355	378	152	224	170	183	224	222	168	153	253	312	228	155		116	142		381	496			394	396
Refrigerator net capacity	litres	355	355	378	147	222	168	181	222	219	167	149	246	308	226	153		110	141		365	477			394	392
Freezer/ice box gross capacity	litres	200	200	213	110	72	106	72	72	72	106		36				106	15		114			320	340		164
Freezer/ice box net capacity	litres	178	178	178	86	63	96	63	63	63	96		36				98	15		98			298	320		138
Features and fittings - fridge																										
bacteriaKontrol	•	•	•	•	•	•	•	•	•	•	•	•	•	•	•	•	•	•	•	•	•	•	•	•	•	•
airVent shelving system					•	•	•	•	•	•	•			•	•	•										
Super cool function	•	•	•									•		•	•	•					•	•				•
Automatic defrost	•	•	•	•	•	•	•	•	•	•	•	•	•	•	•	•	•	•	•	•	•	•	•	•	•	•
Safety glass shelves	4	4	4	4	5	4	4	5	5	4	1		5	7	6	4		3	4		4	4			14	3
Easy adjustable glass shelf	2	1																								
Motorised height-adjustable shelf																					•	•				•
Stainless steel bottle rack	•	•																								
Split shelf				•	•								•	•							•	•				•
Deli drawer	•	•	•																							
Interior light	•	•	•	•	•	•	•	•	•	•	•		•	•	•	•										
Krypton interior light				•	•																					
Halogen interior lighting												•									•	•	•	•	•	•
Number of egg racks	1	1	1	1	2	2	2	2	2				2	2	1	1		1	1		2	2				2
Door bottle gripper				•	•	•	•	•	•				•	•	•	•					•	•				
Number of fresh food containers	2	2	2	2	1	1	1	1	1	1			2	2	1	1		1	1		3	3				3
Temperature controlled drawer	•	•																			•	•				
Humidity controlled fresh food containers	•	•	•	•	•	•	•	•	•	•	•		•	•	•	•					•	•				•
Pull-out fridge tray				•	•	•	•	•	•				•	•	•	•										
Easy adjustable door storage compartment	1																									
Number of door storage compartments	5	5	5	4	6	4	5	6	5	4			7	6	5	4		4	4		4	4				
Number of wine bottles											32															98
Features and fittings - freezer																										
Two temperature zones																										•
Frost free freezer	•	•	•	•	•	•	•	•	•	•	•															•
Freezer star rating <sup>1</sup>	***	**	**	**	**	**	**	**	**	**	**		**				**	**	**	**	**	**	**	**	**	***
Transparent freezer drawers	•	•	•	•	•	•	•	•	•	•	•										•	•				2
Freezer drawers	2	2	2	4	3	4	3	3	3	4							4				3		2	2		
bigBox freezer drawer	•	•	•	•	•	•	•	•	•	•																
Number of ice cube trays				1	1	1	1	1	1				1					1	1							86 ice cubes per day
Ice packs	•	•	•	2	2	2	2	2	2								2									2
Water and ice dispenser	•	•	•																							•
Visual/audible alarm system	•/•	•/•	-/•	•/•	-/•																•/•	•/•				-/•
Super freeze function	•	•	•	•	•	•	•	•	•				•								•	•				•
Adjustable freezer temperature	•	•	•	•	•																•	•				•
Technical information																										
Freezing capacity	kg/24 hours	12	12	12	7	12	6	6	6	4	4		3				12	2		12			14	18		23
Storage time in power failure	hrs	16	16	16	22	22	24	22	22	13	13		18				25	12		24			14	19		22
Energy consumption per 24 hrs <sup>2</sup>	kWh	1.28	1.28	1.52	0.82	0.58	0.79	0.82	0.77	0.77	0.79	0.40	0.71	0.39	0.36	0.34	0.53	0.47	0.32	0.58	0.46	0.50	1.05	0.96	0.85	1.15
Total annual energy consumption <sup>2</sup>	kWh	467	465	557	300	210	288	301	280	280	288	146	259	142	131	122	194	173	118	211	168	181	383	352	310	420
Approximate annual running cost (based on 12p per kWh)	£	56.04	55.80	66.84	36.00	25.20	34.56	36.12	33.60	33.60	34.56	17.52	31.08	17.04	15.72	14.64	23.28	20.76	14.16	25.32	20.16	21.72	45.96	42.24	37.20	50.40
Energy efficiency class <sup>3</sup>		A+	A+	A	A+	A++	A+	A	A+	A+	A+		A+	A+	A+	A+	A+	A+	A	A	A+	A+	B	A+	-	A+
CFC and HFC free		•	•	•	•	•	•	•	•	•	•		•	•	•	•	•	•	•	•	•	•	•	•	•	•
Climate class <sup>4</sup>		SN-T	SN-T	SN-ST	SN-ST	SN-ST	SN-ST	SN-ST	SN-ST	SN-ST	SN-ST	N	SN-ST	SN-ST	SN-ST	SN-ST	SN-ST	SN-ST	SN-ST	SN-ST	SN-T	SN-ST	SN-T	SN-ST	SN-T	SN-T
Noise level	dB (A) re 1 pW	44																								